

lekkie®

BLINGRING OF STEEL 40T 01/02 USER MANUAL

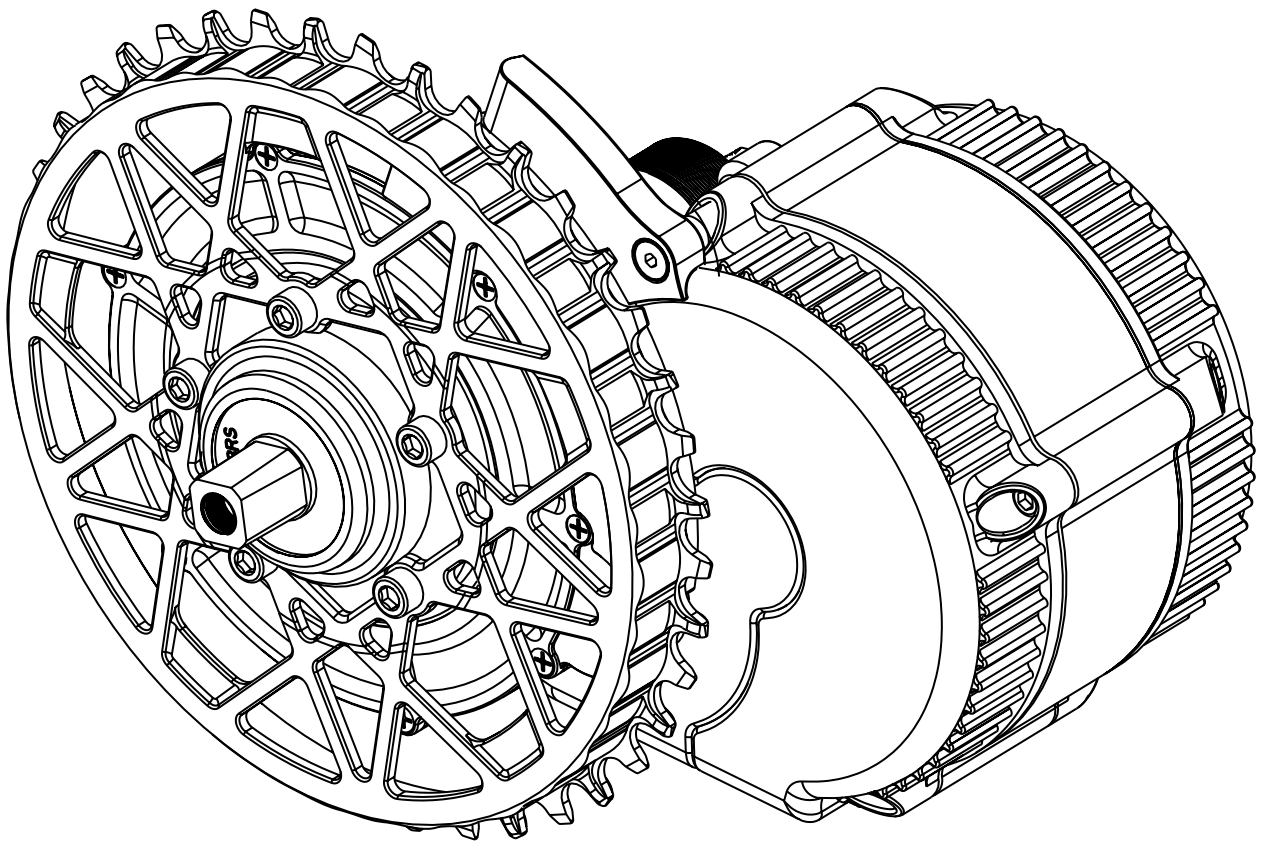

Doc V1.0

PARTS LIST

FOR BLINGRING OF STEEL 40T 01/02 PACKAGE
COMPATIBLE WITH BAFANG BBS01/BBS02

INCLUDES

- A** 1X LEKKIE BLINGRING OF STEEL 40T 01/02
- B** 1X 2MM BLINGRING 01/02 SPACER
- C** 1X DRIVE COVER 01/02 ASSEMBLY
- D** 1X DRIVE COVER 01/02 SPACER
- E** 1X BBS01-02 ANTIJAM

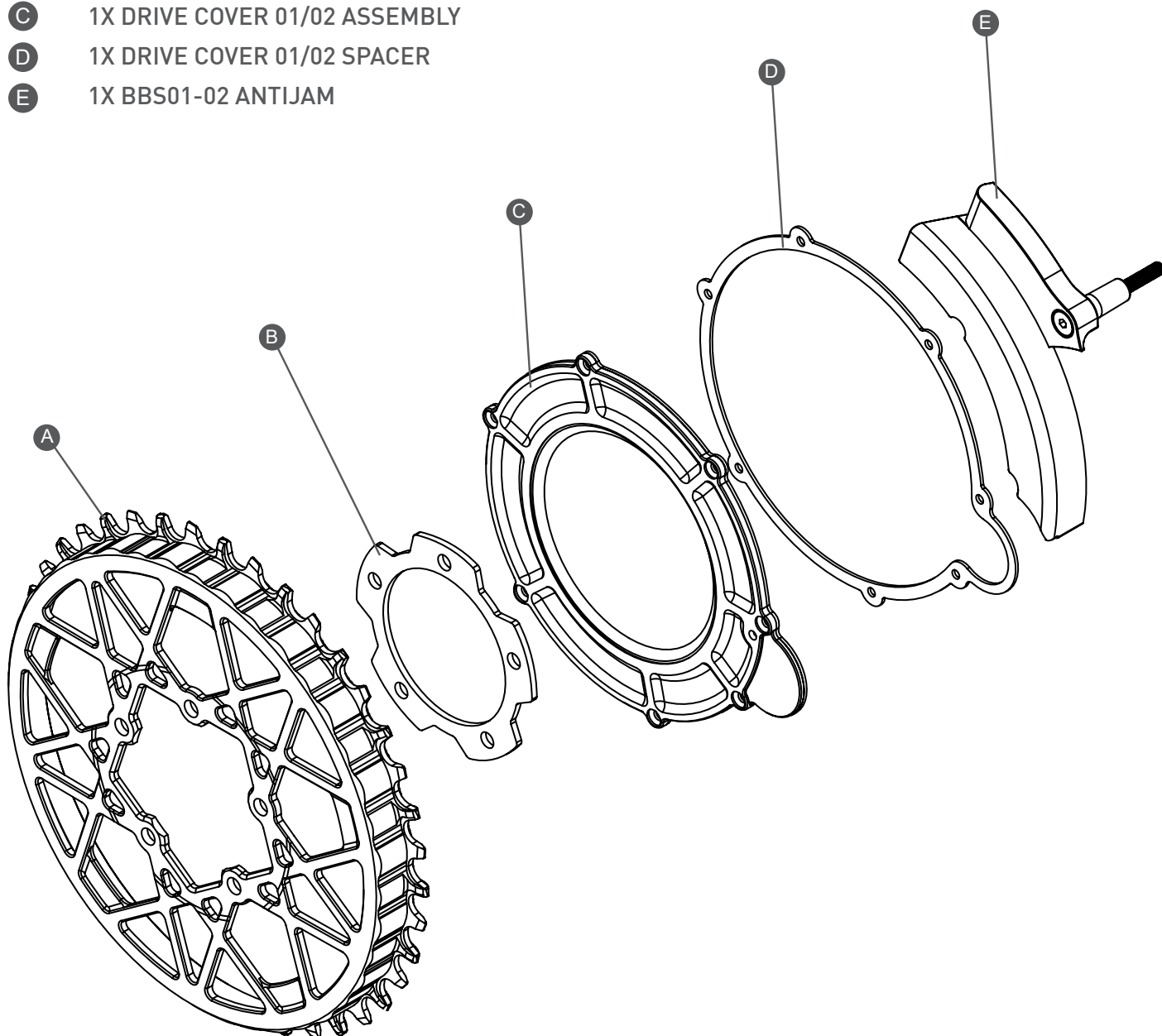

DRIVECOVER INSTALL

The 40T Package includes a replacement DriveCover. This must be installed, as the stock plastic cover will rub on the inner lip of the BlingRing. Failure to install the DriveCover will cause premature wear and subsequent part failure which will not be covered under warranty.

THE 40T KIT INCLUDES

The Lekkie Drive Cover 01/02 has a gasket already assembled onto the cover. These are the parts.

- A** 1X ALUMINIUM DRIVE COVER
- B** 1X RUBBER GASKET (PRE-GLUED)
- C** 1X GASKET SPACER

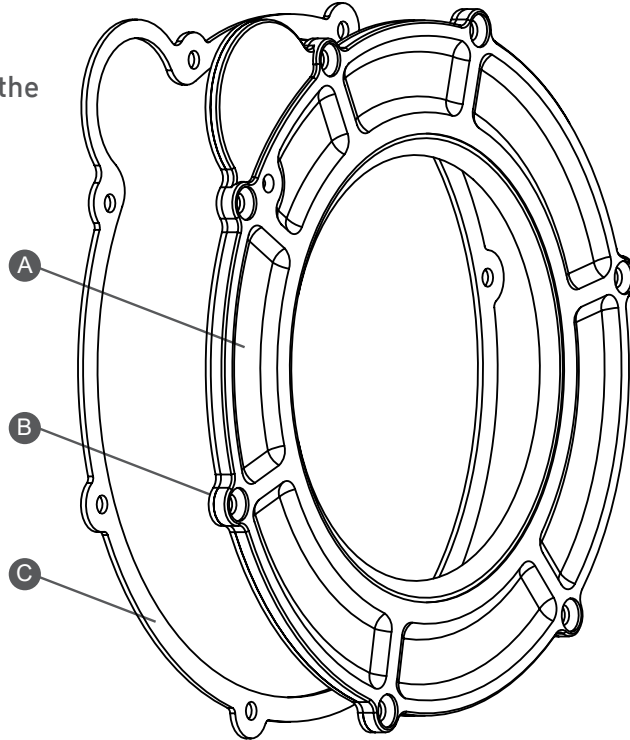

TOOLS REQUIRED

- Phillips screwdriver
- Moly-grease
- All purpose lithium grease
- Loctite 243

Installing the Lekkie Drive Cover 01/02 is straight forward, however you will require some basic tools and mechanical understanding. If you do not have the required tools, confidence or skills to install this, please take your motor to your local bike shop or engineering shop and they should be able to help you out.

INSTALL TIPS

Here are some tips to keep in mind while completing the install.

- If you are installing onto a used motor, thoroughly clean exterior surfaces before removing the Plastic drive cover to avoid dirt/grit contamination.
- To keep everything running smooth and easy to maintain make sure you grease all metal to metal surfaces.
- Clean any excess grease out of the motor while it is open.
- Clean and grease the main gear and pinion (avoid mixing grease types).

INSTALL PROCEDURE

1. Unscrew the screws holding on the stock cover and remove.
2. Clean and lubricate the main drive gear.
3. Clean the mounting surface of the motor body.
4. Wipe a smudge of grease onto the inside edge of the rubber lip of the Lekkie Drive Cover.
5. *Place the spacer gasket on the back surface of the drive cover. Note, the gasket is asymmetrical, please ensure all screw holes are aligned.
6. Place some of the screws through the drive cove/spacer to hold the spacer in position during assembly.
7. Slide the Lekkie Drive Cover onto the motor.
8. Apply a drop of Loctite 243 to each screw and screw them in. Tighten screws until the Gasket is clamped + 1/2 a turn. (Do not over tighten, as gasket may distort).

*Some motors have been found to drag on the underside of the rubber gasket causing excess friction. If this is the case, please use the gasket spacer to increase internal clearance.

GREASE PORT

To keep your motor running its best its important to regularly grease the main drive gear and pinion. We have added a grease port to the Lekkie Drive Cover 01/02 to allow this.

To do so simply use a grease gun with needle point* to squirt moly-grease in while slowly turning the motor.

The port is positioned at the junction of the drive gear and pinion.

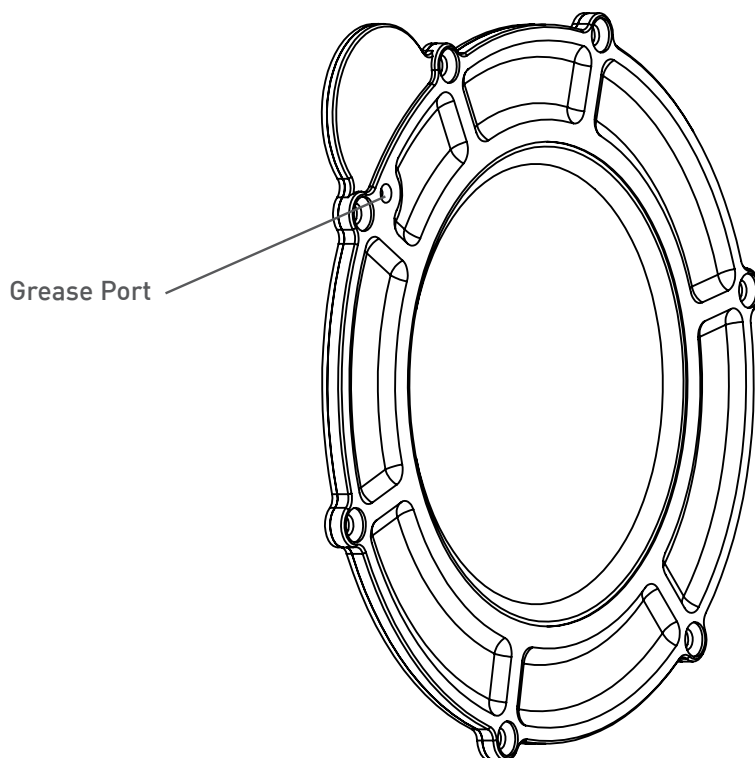

* We recommend the Park Tool GG-1 grease gun, however any grease gun with needle point of appropriate size will work.

01/02 ANTIJAM

The Lekkie Anitjam has been designed to assist with chain retention and prevent chain jams, but also helps eject stones to reduce the chances of getting stones wedged under the 40T Bling Ring, the leading cause for premature failure.

Includes

- 1x Lekkie 01/02 AntiJam (2x parts)
- 2x M3 Plastite screws
- 1x M4 CSK machine screw

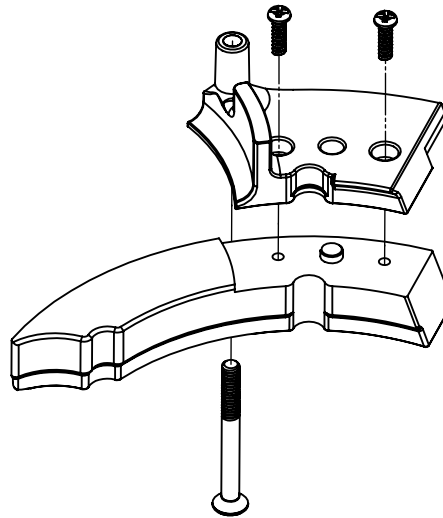

INSTALL TIPS AND TRICKS

Tools Required

- 2.5mm hex key
- 3mm hex key
- PH2 Philips screwdriver

Install

- Assemble the Antijam using the 2x Philips head Plastite screws.

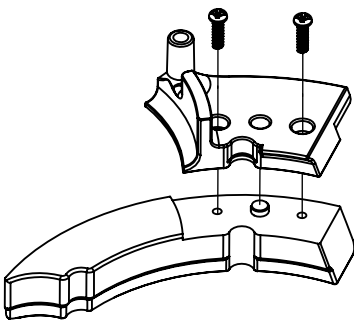

- Remove the top M4 screw holding the controller on, clean out the mounting hole if required
- Assemble onto the motor. Screwing in the M4 CSK to replace the Factory M4 screw.

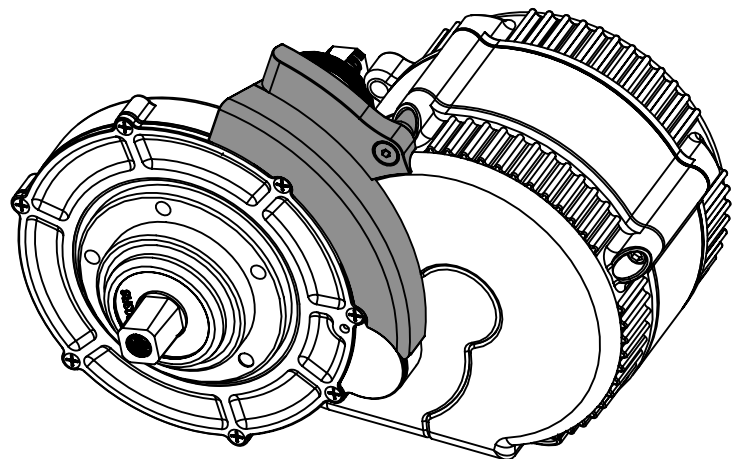
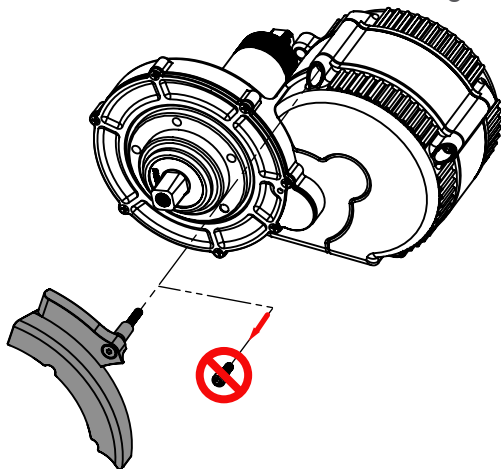

- Ensure the Antijam sits solidly against the motor and controller.

BLINGRING INSTALL

NEXT YOU CAN INSTALL THE BLING RING OF STEEL 40T 01/02

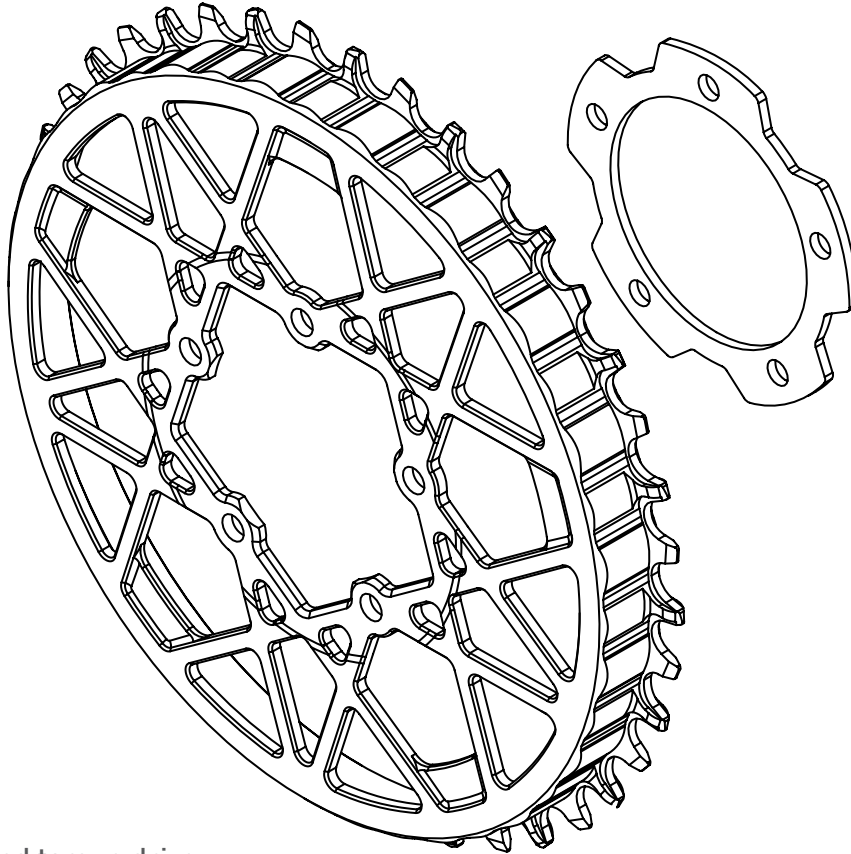

TOOLS REQUIRED

- 4mm hex key and torque drive
- Loctite 243

INSTALL TIPS

- Clean and lubricate axle with a multi-purpose grease before install.
- Always install a new chain when installing a Bling Ring
- If you are using more than one 2mm spacer use longer bolts to ensure adequate thread engagement.
- Make sure when you install your Bling Ring you have at least 1.5mm gap between wide tooth and chainstay to allow flex.
- Try to get the chainline to the centre of your cassette - see below for details.
- Clean and lubricate chain regularly.
- DO NOT use half links in the chain.

INSTALL PROCEDURE

1. Clean the chainring mounting surface.
2. Test fit the Blingring, checking chainline (see chainline below) and clearance to chainstay (and other frame points), clearance to Antijam. Space out using the 2mm spacer if needed. Add spacers as required, adding 2mm to screw length for each spacer.
3. Once satisfied with offset and clearances, prepare the M5 Mounting screws.
4. Apply a drop of Loctite 243 to each screw and screw them in. Tighten alternately to 6Nm
5. Fit a new chain, lining up narrow links with narrow teeth. Lube it up.
6. Re/install the Cranks. Always grease the axle taper before installing cranks.

DIMENSIONS

Here are the basic dimensions of the 40T Bling Ring of Steel.

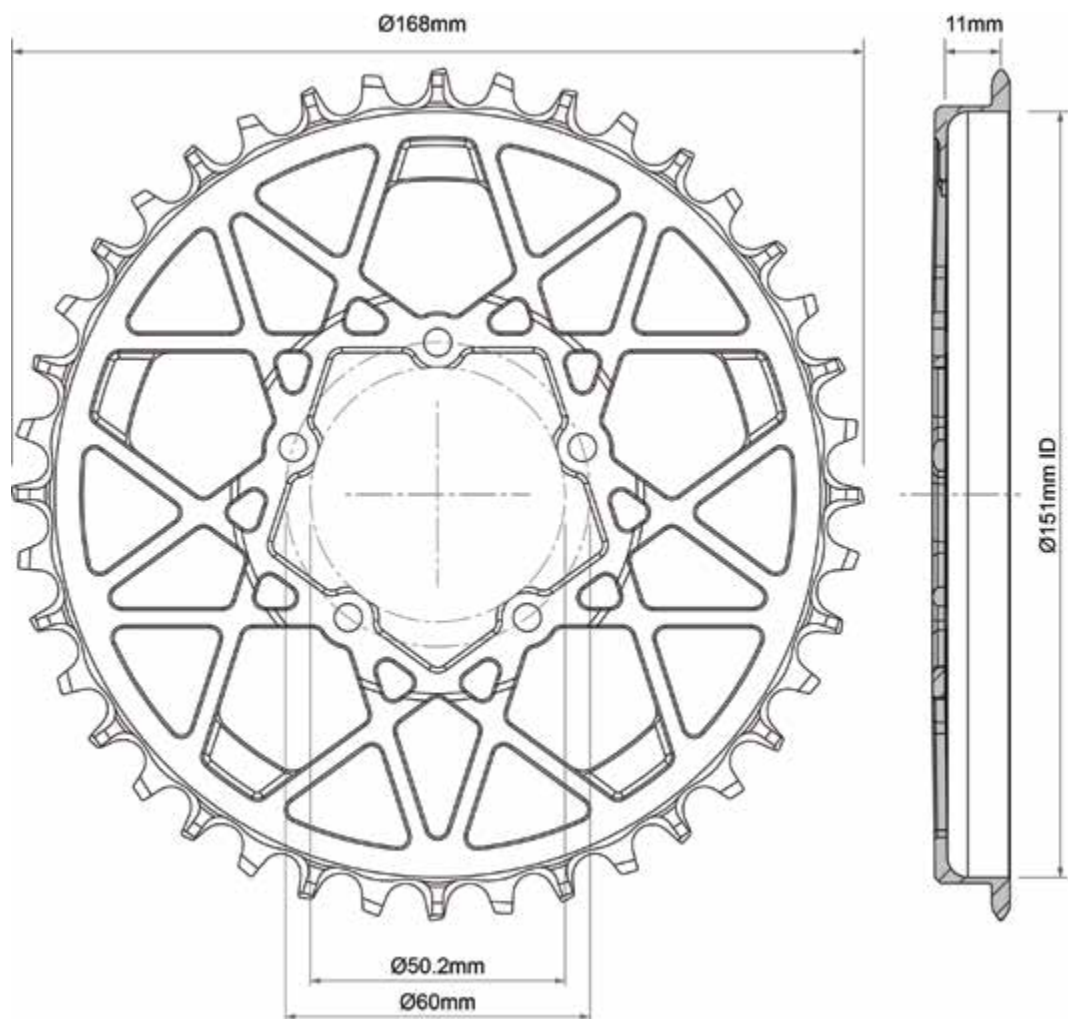

Note the package includes a 2mm Spacer so that you can space the Bling Ring out to the same offset as the original Bling Ring offset. We decided to offset the Bling Ring an extra 2mm so that users could try get that perfect chainline for the 73mm BB frames. If you are building a 73mm BB frame try installing without the spacer. You should have at least 1.5mm gap between the ring and chain-stay.

CHAINLINE

When building your machine you want to replicate the chainline that was on the bike before you converted it. Ideally you want the chainline to line up with the centre of your cassette.

The Blingring is designed to give you the best possible chainline however sometimes you may need to adjust your offset using spacers to get that chainline perfectly suited to the unique geometry of your build.

Some frames will not allow for a central chain line. In this case do the best you can to get the chain central.

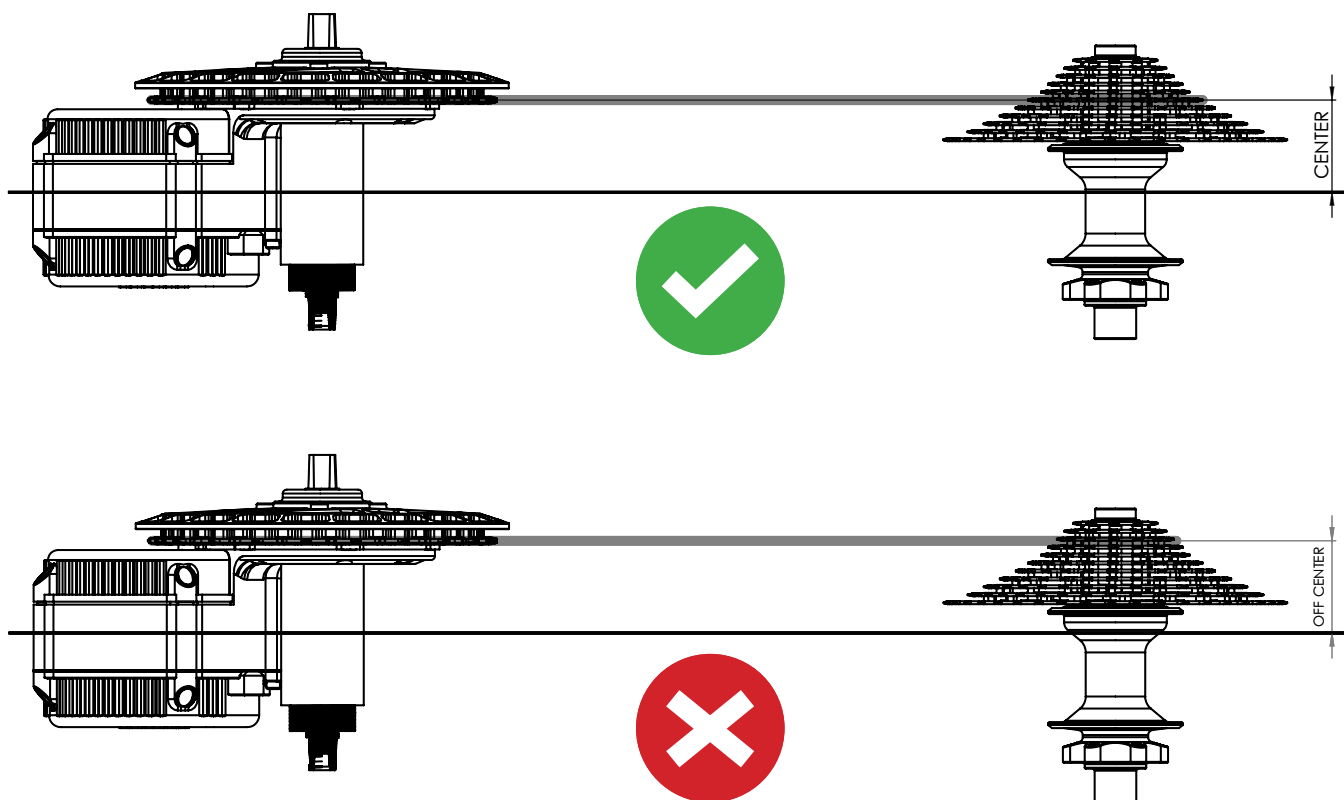

CHAIN COMPATIBILITY

The Lekkie Bling Ring is compatible with most chains up to 11-speed (known to work with some 12 speeds too). If your chain is not sitting well on the chainring try using a Shimano chain compatible with the number of gears. EG HG-X11 11 Speed. Note if the chain is tight on the teeth do not use.

GEOMETRY

Generally the 9/11mm offset found on the 40T BlingRing will give you the best possible chainline without interfering with the motor. However chainstay interference is often the limiting factor. You may need to use Blingring Spacer/s to clear the chainstay.

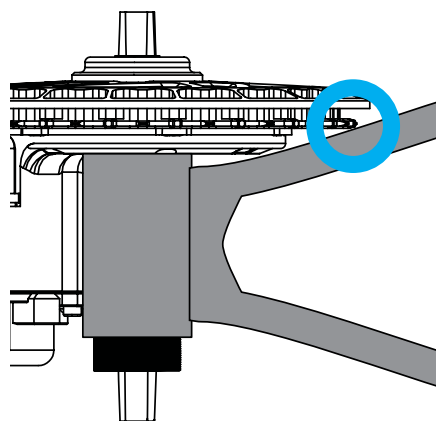

WARRANTY

At Lekkie we don't accept anything but the best workmanship and quality. If a part has slipped through our QC system and made it to your hands let us know and we will put it right.

If one of our products fails we want to know so we can make our products better. If you destroy a lekkie product in extreme use tell us. We can learn from this and sell you something so suit your needs.

If you are in anyway unhappy with your Lekkie product get in touch so we can put it right.