

lekkie[®]

SELFEXTRACTOR CAP V3.1

USER MANUAL

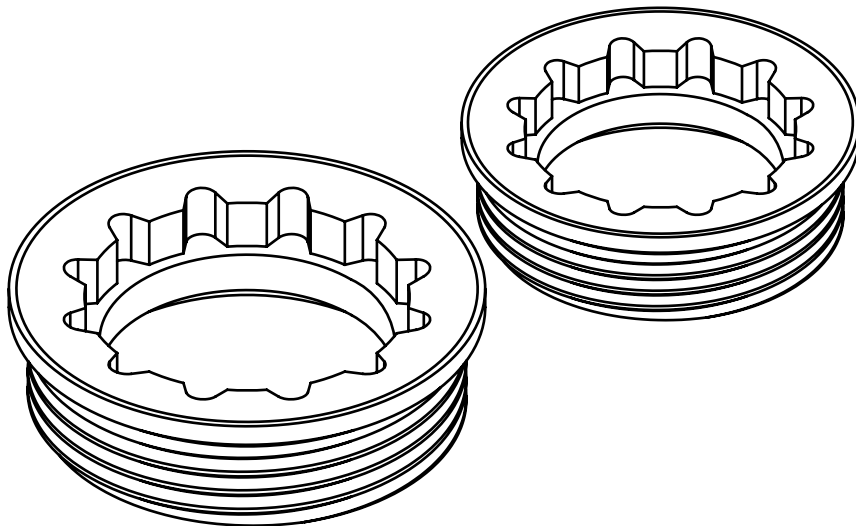

Doc-V2.1

TIPS AND TRICKS

V3.1 EXTRACTOR CAPS FIT BUZZ BARS V3.0 ONLY

INCLUDES

- A** 2X BUZZ BAR EXTRACTOR CAPS V3.1
(BUZZ BAR V3.0 AND BOLT SOLD SEPARATELY)

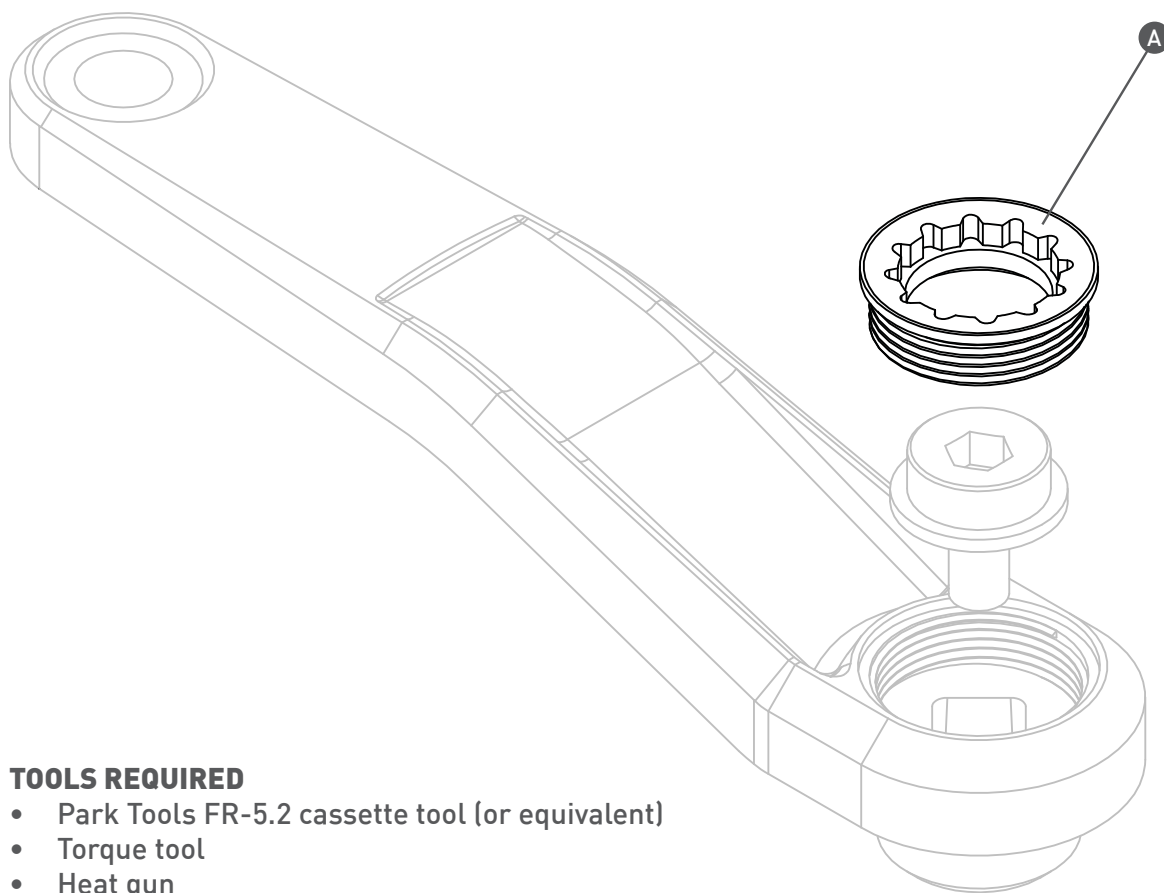

TOOLS REQUIRED

- Park Tools FR-5.2 cassette tool (or equivalent)
- Torque tool
- Heat gun
- All purpose lithium grease
- Loctite 243

INSTALL

1. The cap can be exchanged/installed with the cranks on or off the bike.
2. Apply heat to the extractor cap to soften the factory loctite.
3. Insert **Park Tools FR-5.2** cassette tool into the Buzz Bar Self Extractor V3.1.
4. The Buzz Bar Extractor V3.1 has a **Reverse/left-hand thread** so to unscrew this, **turn the extractor clockwise**.
5. Clean any residual grease from threads.
6. Apply a smudge of multi-purpose grease to the both the underside of the cap and outer top lip of the bolt where it contacts the cap. (avoid getting grease on the thread).
7. Apply a small amount of **Loctite 243** to the thread of the extractor cap and assemble **counter-clockwise** into the crank arm with the cassette tool. Tighten 12-15Nm.
8. Wipe off any excess loctite.

WARRANTY

At Lekkie we don't accept anything but the best workmanship and quality. If a part has slipped through our QC system and made it to your hands let us know and we will put it right.

If one of our products fails we want to know so we can make our products better. If you destroy a lekkie product in extreme use tell us. We can learn from this and sell you something so suit your needs.

If you are in anyway unhappy with your Lekkie product get in touch so we can put it right.